

## ONTOLOGY, EPISTEMOLOGY, CONSCIOUSNESS, AND CLOSED TIMELIKE CURVES

Fred Alan Wolf

**ABSTRACT:** How should we think about subjective states vs. objective states? Is it a question of the meaning associated with a state? Recent work on this question arose in consideration of closed timelike curves (CTCs) and their possible role in quantum computers. The issue of ontic and epistemic states is particularly important when considering CTCs because, as one may argue, the interpretation of quantum states as either ontic or epistemic will naturally lead to different assumptions about how quantum systems behave in the presence of CTCs. For example, David Deutsch studied various time travel scenarios in a classical model and then in a quantum model motivated by a strictly ontic interpretation of quantum states. While in the classical model, CTCs could produce paradoxes, however Deutsch argued that no paradoxes can occur in his parallel universes (modified Everett interpretation) quantum treatment. Although all paradoxes are resolved in this way, the resulting theory is not standard quantum theory, but a new nonlinear theory. Many implications can arise using Deutsch's model and I shall discuss some of them in particular. These assumptions are particularly unconventional in part because they require that mixed quantum states are ontic. Pure quantum states can be interpreted as ontic, however most interpretations view mixed states as epistemic, i.e., reflecting an observer's lack of knowledge. I shall here consider an alternative proposal—pure quantum states, represented by density matrices containing off-diagonal elements, are possibly epistemic (since we never actually see them) while mixed quantum states arising in CTCs are always ontic representing the action of consciousness in observers (we do see them). Paradoxically my argument is based on the well-known experiences of gaining knowledge in classical physics; couching this in quantum physics terms, classical mixed states (represented by diagonal density matrices in quantum physics) are just what arise when an “observation” is said to occur resulting in a so-called reduction of the quantum wave function and the appearance of a classical world. In brief, Deutsch's CTC nonlinear post quantum physics model may represent the action of a conscious mind.

**KEYWORDS:** Ontology; Epistemology; Consciousness

How should we think about subjective states vs. objective states? Is it a question of the meaning associated with state? E.g., is a quantum state to be regarded in the same sense as we regard the state of a ball while at rest or while moving after being struck by a bat? What sort of word should we use to describe the batted ball? Shall we say it is in a state of motion—albeit an observed state of motion—and even more—an objective or ontological state? What if I am not watching the ball or am unable to watch it as it moves, but only capable of surmising the trajectory of it based on the sound of the bat hitting the ball. Should I, based on the smack of the bat on the ball, ascribe a probability distribution to the possible trajectories that may have developed while the ball took its course through the air or on the field of the ballpark? If so, what do I call the state of the unseen, yet struck, ball?

I would certainly surmise, believing that there was a baseball hit by a bat, that it did have a trajectory—an objective ontic state of motion—yet having not seen the ball, but only heard the bat strike, what shall I label the state of the ball under these unseen circumstances? Surely I could and most likely would ascribe a probability distribution to the many possible trajectories such as ascertaining the height of the ball, whether it was foul or fair, how it had top spin or not, etc. Such a probability distribution would be called an epistemic state since my knowledge of the trajectory—that is my knowledge of its ontology—is incomplete.

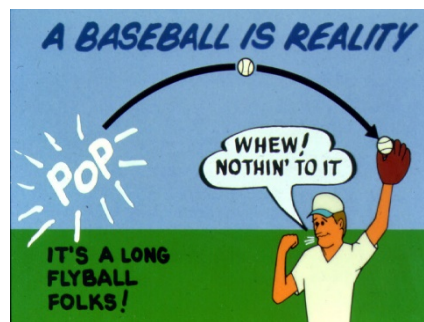

Fig. 1. It's easy if it's ontological.

Here we run into some difficulty having to deal with epistemology or epistemic states. Different epistemic states can describe the same ontic state. E.g., the ball could be considered to have distribution of trajectories and spin possibilities—top spin or back spin—while moving as a fly-ball or as a ground-ball. If the ball had top-spin and was a either a fly- or ground-ball, then both probability distributions are epistemologically correct descriptions. Or consider what happens when I flip a coin and cover it up before anyone can see the face of the coin showing—heads (H) or tails (T). If the coin was a fair

coin, all I can do is assign a distribution of probabilities,  $P_H = 1/2$ , for heads, and,  $P_T = 1/2$ , for tails. Such a distribution would constitute the state of the side of the coin showing as an epistemological state. But suppose I peek at the coin, but don't let you see it. Your knowledge of the coin would remain epistemological while mine would suddenly become ontological because I now know the coin is in the ontological state of, e.g., H.

As another classical epistemic example,<sup>1</sup> consider the case of flipping a biased coin in one of two distinct ways. In the 1<sup>st</sup> way the coin has a probability  $P_1$  of coming up H while in the 2<sup>nd</sup> way the probability for H is  $P_2 \neq P_1$ . If the coin is flipped and then observed any number of times, regardless of the results obtained, we cannot know for certain by which method the coin was flipped, although the observed frequency of H resulting could provide a clue provided we knew that the same preparation was used for each flip. Not knowing this, the result, H, could have been obtained with either mode of flipping. Hence we cannot assign uniquely either probability  $P_2$  or  $P_1$  and these probabilities remain epistemic although the unobserved method of flipping need not be so.

In another classical epistemic example<sup>2</sup>, consider a die prepared in a manner that shows the value 2 with a predicted probability of  $1/3$ . We cannot know if the die was prepared in such a way that only prime numbers (2, 3, or 5) were allowed to show (it had these numbers repeated on opposite sides), or if only even numbers (2, 4, or 6) were allowed to show. Each distribution has the number 2 in common, so the distributions are conjoint and epistemic.

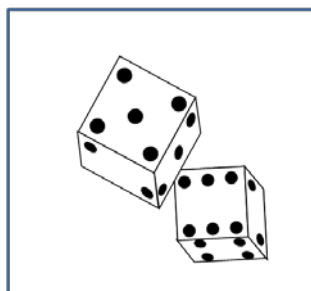

Figure 2. Loaded dice, but which way?

---

<sup>1</sup> M. F. Pusey, J. Barrett, and T. Rudolph. "On the reality of the quantum state." <http://arxiv.org/abs/1111.3328v2>. Also see: Nature Physics (2012), published online 06 May 2012.

<sup>2</sup> E. S. Reich. "A boost for quantum reality." Nature Vol. 485. 10 May 2012. pp 157-8.

## QUANTUM PHYSICS: EPISTEMOLOGY OR ONTOLOGY?

When we begin to look at quantum physics such questions of epistemology and ontology rise up again and for many in a confusing or perplexing manner. Along this line, in a remarkable remark, physicist E. T. Jaynes once stated:

We believe that to achieve a rational picture of the world it is necessary to set up another clear division of labor within theoretical physics; it is the job of the laws of physics to describe physical causation at the level of ontology, and the job of probability theory to describe human inferences at the level of epistemology. The Copenhagen interpretation scrambles these very different functions into a nasty omelet in which the distinction between reality and our knowledge of reality is lost.<sup>3</sup>

An ontological model attempts to logically illustrate in a one-to-one manner a theory that explains observable predictions. It provides a systemic map wherein every state is completely specified by the values of a set of variables within the theory. The ontic state describes such objective attributes of a physical system, regardless of what anyone knows about that system. Hence in the baseball example the ball's trajectory is an ontic state even though we may or may not know it.

In what follows I shall use the adjectives ontic and epistemic to modify a number of nouns such as physics, beliefs, observables, and reality as most of us currently understand these things. Hence ontic reality is what we accept as real and "out there" objectively independent of anything we have to say, believe, or know about it. Epistemic reality, on the other hand, is what we accept as real and "in here" subjectively dependent on what we think, know, or believe is either ontic or epistemic reality.

In the case of quantum mechanics, we have two contrasting theories of an ontological model (a.k.a. ontology): Bohmian mechanics<sup>4</sup> and Everettian parallel universes.<sup>5</sup> One might add to these interpretations, the decoherence model<sup>6</sup> wherein all possible branches of the quantum wave function separately decohere from each other.

---

<sup>3</sup> E. T. Jaynes. "Clearing up mysteries." In the Proceedings Volume: Maximum entropy and Bayesian methods. J. Skilling (ed.). Kluwer Academic Publ. Dordrecht, Holland (1989). pp 1-27.

<sup>4</sup> Bohm, D., 1952, "A Suggested Interpretation of the Quantum Theory in Terms of 'Hidden' Variables, I and II," *Physical Review*, 85: 166–193. Also see: Bohm, D., and Hiley, B. J., 1993, *The Undivided Universe: an Ontological Interpretation of Quantum Theory*, London: Routledge & Kegan Paul.

<sup>5</sup> Dewitt Bryce S. and Graham, Neill. *The Many-Worlds Interpretation of Quantum Mechanics*. Princeton, New Jersey: Princeton Univ. Press, 1973.

<sup>6</sup> Zurek, Wojciech H. (2003). "Decoherence and the transition from quantum to classical — REVISITED", arXiv:quant-ph/0306072 (An updated version of *PHYSICS TODAY*, 44:36–44 (1991) article).

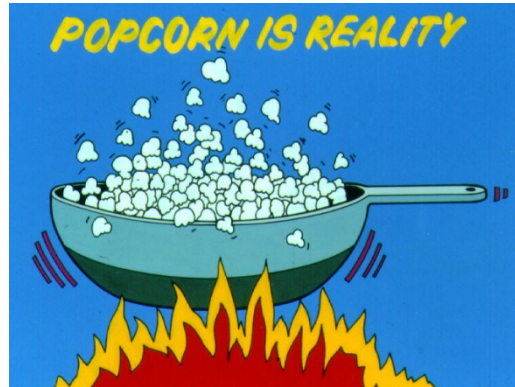

Fig. 3. Epistemic popcorn?

The Bohmian (de Broglie–Bohm) theory, also known as the pilot-wave theory, Bohmian mechanics, the Bohm or Bohm’s interpretation, and the causal interpretation, is an ontological interpretation of quantum theory. In addition to a “real” wavefunction existing on the space of all possible configurations, it also postulates an actual configuration of particles that exist even when unobserved. In the double-slit drawing below the wavefunction for a single particle is defined at both slits, but the particle nevertheless has a well-defined trajectory that passes through exactly one of the slits. The final position of the particle on the detector screen and the slit through which the particle passes is determined by the initial position of the particle just as a classical baseball’s position is determined by how it hit the bat.

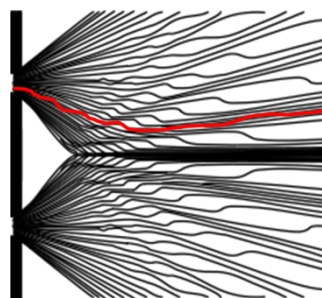

Fig. 4. Bohmian model of the 2-slit experiment with a real trajectory of a particle shown in red.

The Everettian, parallel universes, or many-worlds interpretation of quantum mechanics also asserts the ontological reality of the universal wavefunction and denies the actuality of wavefunction collapse. Many-worlds imply that all possible alternate histories and futures are real, each representing an actual “world” (or “universe”).



Fig. 5. Parallel Universes for Schrödinger's cat.

### IS COLLAPSE OF THE QUANTUM WAVE FUNCTION JUST MAJA?

However, the interpretation that most physicists accept, although usually not acknowledged, is the old-fashioned Bohr or Copenhagen interpretation wherein the state of a quantum system remains in an omelette phase of being both ontological and epistemological at the same time until an observation takes place and one says the wave function has collapsed. Inherent in this view is an apparent reason for this “sudden” collapse—namely the appearance of a conscious mind—an observer whose actions cause the collapse wherein the omelette becomes an ontological state observable for all to see. Is there any way to get out of this collapse position and do any of the other interpretations take into consideration the nature of a mind in the role of observations?

Well let's see what happens when an observation is said to occur. Let's say before the observation that the Schrödinger cat state represented by a quantum wave function is given by a superposition of two possibility amplitudes  $L$  (live cat) and  $D$  (dead cat). Now this state, which we can label as  $S$ , turns out to be a mathematical sum  $S=L+D$ . The problem is that both  $L$  and  $D$  represent quantum wave functions; hence they are wavy having both amplitudes and phases. To determine what is what, epistemologically with either possibility occurring, one must “square” these waves by multiplying each by its complex-conjugate. Hence the probability of a dead cat is  $D^* \cdot D$  and the probability of a live cat is  $L^* \cdot L$ . Such a “squaring” is said to take place upon the act of observation

and then  $S$  (actually  $S^* \cdot S$ ) becomes a mixture of  $L^* \cdot L + D^* \cdot D$  wherein there is no interference between the two possibilities as one would expect based upon common sense. However if no observation occurs the state contain interference terms as per  $S^* \cdot S = (L^* + D^*) \cdot (L + D)$  in which the interference terms  $L^* \cdot D$  and  $D^* \cdot L$  are present. But these interference terms  $L^* \cdot D$  and  $D^* \cdot L$  are not observed—all we observe is either  $L^* \cdot L$  or  $D^* \cdot D$ .<sup>7</sup> The important point here has to do with what constitutes an observation or measurement. In classical physics such as in the case of the flipped coin, e.g., the result of bringing the experiment to a conclusion is that our knowledge of the upturned face of the coin is epistemological and consists of (in quantum physics terms) the probability distribution  $H^* \cdot H + T^* \cdot T$ . Once an observation occurs we know the result is heads ( $H^* \cdot H$  in quantum physics terms) or tails ( $T^* \cdot T$ ). We can imagine, although such a picture is clearly not needed in this classical physics case, that the result  $H^* \cdot H$  takes place on one universe while the result  $T^* \cdot T$  takes place in a parallel universe. However such an imagining may play a key role in the quantum physics case.

To deal with this let's first review some quantum physics as it might apply to the brain. Following Ludwig Bass's presentation,<sup>8</sup> usually in many attempts to apply quantum physics to the brain and nervous system, "consciousness" is used as a single unanalyzed entity in which upon an observation a train of impulses from one neuron to another may or may not be noted as a datum. However, physiology suggests that mind and the associated consciousness should be viewed as "a collection of quasi-independent perceptual minds integrated in large measure by temporal concurrence of experience."<sup>9</sup> Such considerations have been reinforced by the results of research dealing with the splitting of brain hemispheres, which supply anatomical parallels to the concept of quasi-independent minds.

Thus the possibility arises that a quasi-independent mind (in Sherrington's sense, see footnote 9) brings about the reduction of the wave function thus becoming a datum in the integrated and introspected consciousness. This hypothetical situation is paralleled in quantum physics by the concept of "Wigner's friend." Two independent observers, say Alice (we shall use  $A$  to denote Alice) and Bob ( $B$  for Bob) are introduced: we label

---

<sup>7</sup> In the double slit and other experiments such interference terms can be observed provided one upon observation cannot determine which slit a particle passes through. In the case of the cat one must be able to observe a superposition of both  $D$  and  $L$  for which no measurement is possible.

<sup>8</sup> Bass, Ludvik. "The Mind of Wigner's Friend," *Hermathena: A Dublin University Review*, no. 112, (1971) pp. 52-68. Bass was a student of Erwin Schrödinger.

<sup>9</sup> Sherrington, C. S. *Man on His Nature* (Cambridge Univ. Press, London, 1940). Sherrington elaborated this on the example of the two eyes in man," concluding: "It is much as though the right- and left-eye images were seen each by one of two observers and the minds of the two observers were combined to a single mind."

the intermediate observer, A, and one of many possible ultimate observers, B, each endowed with the ability to reduce a wave function by an event in her or his consciousness. B considers the joint wave function of a cat in a box, C, and Alice, A. The result which is important for the present purpose is obtained when one of the states of the cat, L or D, (shown in Fig. 6 as a movement of the quantum wave function to the left as L and the right as D) enters the consciousness of A: L or D becomes for A either a live or a dead cat, but for the ultimate observer, B, the joint state of the object-plus-intermediate observer becomes a mixture<sup>10</sup> of the two joint eigenstates say  $A_L \cdot L$  and  $A_D \cdot D$ . This mixture is for B has no interference terms. It consists of the state  $B \cdot B = (A_L \cdot L) \cdot (A_L \cdot L) + (A_D \cdot D) \cdot (A_D \cdot D)$ .

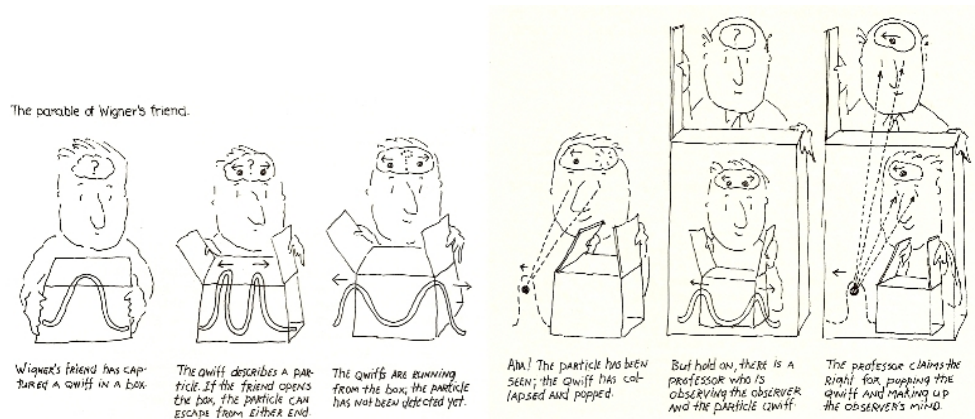

Fig. 6. "Wigner's friend" parable (qwiff stands for quantum wave function).<sup>11</sup>

In the "Wigner's friend" model the role of the ultimate observer B—that of the integrated and introspected consciousness—may be played by any of the quasi-independent minds,  $A_i$ , with  $i$  being any integer. Then the reduction of the wave function may occur when any quasi-independent mind,  $A_i$ , within the observer records the relevant datum, while for the integrated and introspected mind, B, the state of the neural net is in a mixture of the two states.

<sup>10</sup> This means that the object-plus-intermediate observer are, in actual fact, in one or the other state given by alternatives, but the ultimate observer can know only the probabilities of these states until he communicates with the intermediate observer.

<sup>11</sup> Taken from Wolf, Fred Alan. *Taking the Quantum Leap. The New Physics for Nonscientists*. San Francisco: Harper & Row, 1981. Revised edition, New York: HarperCollins, 1989, pp 216-217.



So a key insight here is to note the difference between a mixture of possible states and a coherent superposition of such states. It is the paradoxical aspects of this difference that I wish to discuss further. It may be relevant to observe that there may be an apparent physiological insignificance of the difference between the establishments of a superposition of two states,  $(A_L \cdot L + A_D \cdot D) * (A_L \cdot L + A_D \cdot D)$ , or a mixture of the two states,  $(A_L \cdot L) * (A_L \cdot L) + (A_D \cdot D) * (A_D \cdot D)$ . They may have the same physiological effect as either one of the states,  $(A_L \cdot L) * (A_L \cdot L)$  or  $(A_D \cdot D) * (A_D \cdot D)$ .

This feature seems to be consistent with a commonly experienced phenomenon: An initially consciously directed action gradually becomes automatic through frequent repetitions<sup>12</sup> yet the process of fading from consciousness leaves the actual muscular movements entirely unchanged. However perhaps in cases involving schizophrenia such a difference may manifest.

## INTRODUCTION OF SUB-BRAINS

Following Bass once again,<sup>13</sup> brain research may be indicating that each individual's consciousness may be showing a multitude of consciousnesses. But is the true? As we have seen above, in the famous Wigner paradox an ultimate observer B tells an intermediate observer A that it was he, B, that really chose the outcome of observation and that A was really in parallel conflicting realities. Yet, if the plurality of conscious minds is an illusion, it becomes surprising that the ultimate observer B must ask questions of the intermediate observer A in order to discover the contents of their supposed one consciousness. One would rather expect a direct telepathic knowledge, which in our accustomed pluralistic language, would be described as telepathy between any two such observers. Yet we know that if telepathy exists at all, it is a weak and uncontrollably erratic phenomenon. In Indian terms, the veil of Maja must be very effective. Can its effectiveness be accounted for in scientific rather than mythical terms?

The essential scientific insight has been pointed out by J. B. S. Haldane: "We should expect such phenomena [leakage from one mind to another] to be unusual as, from the standpoint of natural selection, a person who habitually experienced other people's sensations would probably be less fit than a normal person. I should not be surprised if our mental insulation turned out to be a special adaptation."<sup>14</sup> An adaptation, which would yield a favorable coupling of one mind with the many bodies involved in the

---

<sup>12</sup> This "gradual fading from consciousness is of outstanding importance to the entire structure of our mental life, which is wholly based on the process of acquiring practice by repetition."

<sup>13</sup> Also see, Bass, L. "A Quantum Mechanical Mind-Body Interaction." *Foundations of Physics*. Vol. 5, No. 1, March, 1975.

<sup>14</sup> Haldane, J.B.S. and Lunn, A. *Science and the Supernatural*. London, UK: Eyre and Spottiswoode, 1935.

evolution of species.

From the Vedantic point of view, Haldane's remark is the most important of all insights furnished by the theory of evolution. The genetic fixation of the proposed insulating adaptation would be one amongst the many recognized constraints exerted by the body on mind. But we know that such genetic fixations are subject to variations. Surprising results of future mutations, or even of combinations of existing recessive mutations, would have to be admitted as possible. Some existing species might be shown to be deficient in the insulating adaptation between members of that species.

A complementary problem may also be elucidated from the evolutionary point of view. Sherrington discussed in detail the plurality of entities in any one living body which all seem physiologically as capable of having separate minds as different bodies themselves: "How far is the [individual] mind a collection of quasi-independent perceptual minds integrated physically in large measure by temporal concurrence of experience?"

Such integration may be viewed as a complementary adaptation of the individual vehicle of natural selection: that is, Haldane's insulating adaptation may be complemented by a total lack of insulations within the selected domain of physico-chemical processes called "the individual body". The veil of Maja is absent so completely between Sherrington's quasi-independent perceptual minds that not even a suspicion of plurality within the human individual comes about until the onset of abstract speculation; no one speaks of this integration as perfect telepathy. The presence and absence of the veil, respectively, are so perfect in the two contrasting aspects that Schrödinger could advance his empirical argument: "consciousness is never experienced in the plural." Maja too is tied to the wheel of evolution.

"How does the idea of plurality arise at all?" asks Schrödinger. "Consciousness finds itself intimately connected with, and dependent on, the physical state of a limited region of matter, the body. Now, there is a great plurality of similar bodies. Hence the pluralization of consciousnesses or minds is a very suggestive hypothesis."

It is clear that in order to suggest a plurality of independent minds, the similar bodies must themselves be independent of each other in the sense that their interactions must be mediated by physical agents which may be arbitrarily reduced, for example, by sufficiently increasing the distance between the bodies. It is remarkable that such independence is severely restricted, for an important class of cases, by the quantum theory of correlated systems; that is, by the argument against the plurality of conscious

minds. The restriction follows from the argument of Einstein, Podolsky, and Rosen<sup>15</sup> (**EPR** for short) by means of the interpretation (unintended by these authors) which would maintain the completeness of quantum mechanics.

If we follow Bohr,<sup>16</sup> the suggestive force of a plurality of bodies, leading to the hypothesis of plurality of conscious minds, is greatly weakened. It is to be noted that this loss of independence occurs only for pairs of bodies which had previously interacted closely enough to establish a correlation. This seems usually possible for pairs of subjects suspected of being in telepathic communication.

In this context Einstein reports<sup>17</sup> “a conversation which I had with an important theoretical physicist. He: ‘I am inclined to believe in telepathy.’ I: ‘This has probably more to do with physics than with psychology.’ He: ‘Yes.’” In the present context there is the possibility that telepathy may be a matter of physics, the non-existence or weakness of telepathy may be a matter of natural selection.

So all of this Maja brain modeling is based on the old point of view of Bohr-Wigner—there must a collapse of the quantum wave function. But is this the only way out of this seeming paradoxical thinking? Perhaps we can look at what happens before we enter into spacetime at all. For by collapse do we not all tend to think of a wave just instantaneously popping like a balloon? But so far, there is no known theoretically consistent quantum physical manner for modeling this collapse. Closest to it are perhaps the non-collapsible Bohmian and Everettian interpretations. Yet these do not include consciousness in any manner.

Here I now come to the premise of my article. Consciousness acts, but not in spacetime itself, but in what might be called pre-spacetime—an abstract “space” governed by algebraic quantum computation involving what are labeled as qubits, unitary gates, and rails carrying the qubits into and out of the gates that act to transform the qubits. From this pre-spacetime quantum computation, spacetime and consciousness of events wherein emerge.

## ONTOLOGY AND EPISTEMOLOGY OF CLOSED TIMELIKE CURVES (CTC)

A fundamental issue that interpretations of quantum mechanics seek to address is the

---

<sup>15</sup> Einstein, Albert; Podolsky, Boris; and Rosen, Nathan. “Can The Quantum-Mechanical Description of Physical Reality Be Considered Complete?” *Physical Review*. Vol. 47 (1935), p. 777.

<sup>16</sup> Bohr, Niels. *Atomic Theory and the Description of Nature*. Cambridge, London: Cambridge Univ. Press, 1934.

<sup>17</sup> Reichenbach, H. *Einstein: Philosopher-scientist*. (ed. Schlipp, P.A.) Evanston IL: The Library of Living Philosophers, 1949.

relationship between the mathematical formalism of quantum mechanics and physical reality (if a physical reality is assumed to exist). As I said, that issue is whether quantum states are ontic or epistemic states. Let me call the putative quantum physical states “omelet” states as per Julian Jaynes’s remarks above and briefly review some arguments. The ontic state of a system is the physical (i.e. objective) state that the system is “in”—that is physically “out there,” whereas an epistemic state of a system reflects the observer’s knowledge about the system—that is mentally “in here.” An epistemic state is typically a probability distribution over the space (possibilities, represented as complex probability functions) of orthogonal ontic states. From these definitions, one can see that the ontic state of a system is uniquely observable, while epistemic states in general are not (i.e., different observers can describe a system by different epistemic states).

While it certainly doesn’t seem obvious; the “omelet” question may have resolution coming from quantum computers—in particular, circuits representing the flow of data—qubits—from one state to another. Quantum computational circuits act upon data that can be represented mathematically in various formats. In a normal quantum computation two or more qubits enter a transforming *gate* together. Each qubit is pictured to move along a given “rail.” Next one looks for changes in one or more of the qubits determined by a 2<sup>nd</sup> control qubit. The unitary “gate” that acts as a transformer for the variable qubit depending on the value of the controlling qubit. One of the simplest gates is called the “measurement” or “controlled-not” gate. Given that the controlling qubit entering along rail 1 has value  $a$  (either a 0 or 1) and the variable qubit entering along rail 2 has value  $b$  the output variable qubit takes on the value  $a \oplus b$ ,<sup>18</sup> where the circled plus sign indicates summation modulo 2 (wherein  $1 \oplus 1 = 0 \oplus 0 = 0$ , and  $1 \oplus 0 = 0 \oplus 1 = 1$ .)

A typical two qubit “measurement” circuit looks like figure 7:

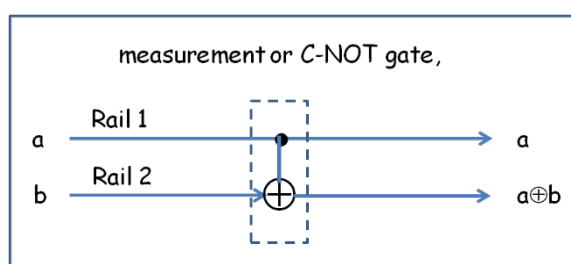

Fig. 7. A simple quantum computer circuit using a controlled-NOT gate (CNOT).

<sup>18</sup> Here we use binary arithmetic modulo 2, so that  $0 \oplus 0 = 0$ ,  $0 \oplus 1 = 1$ , and  $1 \oplus 1 = 0$ .

In the Fig. 7, the qubit marked **a** represents a controlling input to the gate shown enclosed in a dotted rectangular box, while the qubit marked **b** represents an input to be transformed according to the  $\oplus$  symbol that represents **NOT** or the opposite of the input **b**. The **NOT** gate operates to flip **b** to **not-b**, if the input **a=1**, but to not act if **a=0**. Generally speaking one is carrying out a quantum computing calculation through the use of such gates as shown above.

For many uses a qubit, say **a**, is represented as *ket* vector,  $|a\rangle$ , that has the computational basis value,  $|0\rangle$  or  $|1\rangle$ . A general qubit has the form  $|a\rangle = \alpha|0\rangle + \beta|1\rangle$  where  $\alpha$  and  $\beta$  are complex numbers.

One may also use the *density matrix* or *ket-bra* format,  $|a\rangle\langle a|$ , to represent a qubit, wherein the general qubit has the form:

$$|a\rangle\langle a| = (\alpha|0\rangle + \beta|1\rangle) \otimes (\alpha^*\langle 0| + \beta^*\langle 1|) = |\alpha|^2 \mathbf{00} + |\beta|^2 \mathbf{11} + \alpha\beta^* \mathbf{01} + \beta\alpha^* \mathbf{10}. \quad \text{eqn. 1}$$

In eqn. 1, the condition  $|\alpha|^2 + |\beta|^2 = 1$  holds as per the Born rule for quantum physics. I have used a simpler notation that I invented by simply writing,  $|a\rangle\langle b| \equiv \mathbf{ab}$ , and then the following rules hold as to how these *ket-bras* (density matrices) are to be multiplied as either dot,  $\bullet$ , or cross (tensor)  $\otimes$ , products. The rule is:

$$|a\rangle\langle b| \bullet |c\rangle\langle d| = \mathbf{a} \bullet \mathbf{b} \bullet \mathbf{c} \bullet \mathbf{d} = \mathbf{a} \bullet \mathbf{d} = |a\rangle\langle d| = \mathbf{ad}, \text{ if and only if } \mathbf{b} = \mathbf{c}. \quad \text{eqn. 2a}$$

Therefore  $\mathbf{ab} \bullet \mathbf{cd} = \mathbf{0}$ , if  $\mathbf{b} \neq \mathbf{c}$ . I'll not use the  $\otimes$  sign when it is understood that two qubits written as  $\mathbf{ab}$  imply  $\mathbf{a} \otimes \mathbf{b}$ .<sup>19</sup> In what follows I'll be using the density matrix format to represent qubits and quantum computer gates as shown in Fig. 8. In eqn. 1 we have:

$$\mathbf{00} = \begin{pmatrix} 1 & 0 \\ 0 & 0 \end{pmatrix}, \quad \mathbf{01} = \begin{pmatrix} 0 & 1 \\ 0 & 0 \end{pmatrix}, \quad \mathbf{10} = \begin{pmatrix} 0 & 0 \\ 1 & 0 \end{pmatrix}, \quad \mathbf{11} = \begin{pmatrix} 0 & 0 \\ 0 & 1 \end{pmatrix}, \quad \text{and } \mathbf{I} = \begin{pmatrix} 1 & 0 \\ 0 & 1 \end{pmatrix},$$

eqns. 2b

where **I** is the identity matrix. We note that  $\mathbf{I} = \mathbf{00} + \mathbf{11}$ . I shall also use:

---

<sup>19</sup> These rules follow directly from the rules of matrix multiplication. See e.g., Nielsen, Michael A. and Chuang, Isaac L. *Quantum Computation and Quantum Information*. Cambridge University Press; 10<sup>th</sup> Anniversary ed. edition (January 31, 2011).

$$\mathbf{X}=\mathbf{01}+\mathbf{10},$$

eqn. 2c

in what follows. One can recognize  $\mathbf{X}$  as the Pauli spin-x operator,  $\sigma_x$ . Consequently the measurement gate or controlled-not, **C-NOT**, gate is expressed simply as  $(\mathbf{00}\otimes\mathbf{I}\oplus\mathbf{11}\otimes\mathbf{X})$ .

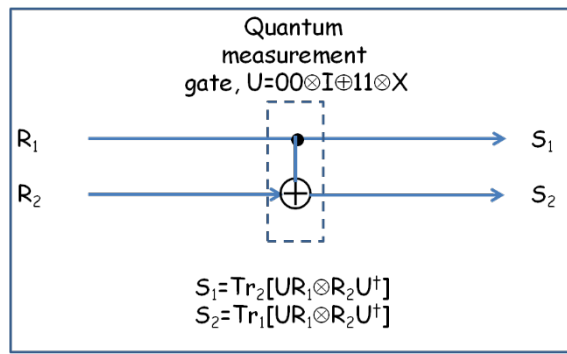

Fig. 8. A quantum Measurement gate in action. Time flows from left to right.

In the above circuit, e.g., given  $\mathbf{R}_1=\mathbf{11}$ , and,

$$\mathbf{R}_2=(\alpha|\mathbf{0}\rangle+\beta|\mathbf{1}\rangle)\otimes(\alpha^*\langle\mathbf{0}|+\beta^*\langle\mathbf{1}|)=\alpha\alpha^*\mathbf{00}+\beta\beta^*\mathbf{11}+\alpha\beta^*\mathbf{01}+\beta\alpha^*\mathbf{10}, \quad \text{eqn. 3}$$

we then calculate using the trace formulas shown in figure 8,  $\mathbf{S}_1=\mathbf{R}_1=\mathbf{11}$ , and,

$$\mathbf{S}_2=(\alpha|\mathbf{1}\rangle+\beta|\mathbf{0}\rangle)\otimes(\alpha^*\langle\mathbf{1}|+\beta^*\langle\mathbf{0}|)=\alpha\alpha^*\mathbf{11}+\beta\beta^*\mathbf{00}+\alpha\beta^*\mathbf{10}+\beta\alpha^*\mathbf{01}. \quad \text{eqn. 4}$$

Hence the gate flips the bits of input  $\mathbf{R}_2$  to arrive at output  $\mathbf{S}_2$ . Note that  $\mathbf{Tr}_1$  means tracing over the first density matrix while  $\mathbf{Tr}_2$  means tracing over the second density matrix found in the tensor product of  $\mathbf{UR}_1\otimes\mathbf{R}_2\mathbf{U}^\dagger$ . All of this is standard quantum computer boilerplate.

The interesting question here is: can we make an extension of quantum physics (we might call this post quantum physics, or PQP) to find a way of understanding just how a measurement occurs, in particular what the event of “measuring” has to do with consciousness? Is there a PQP theory which includes the action of a conscious observer? If so what should we expect from the theory? I’ll provide a brief answer here. It is simple

to state: Consciousness acts by stripping off the off-diagonal elements of the density matrix representing the observed state. The result, e.g., for a quantum physics coin-flip with  $h$  being the complex probability amplitude for heads and  $t$  being the complex probability amplitude for tails; we find the state:

$$hh^*00 + t^*t11 + ht^*01 + h^*t10 \rightarrow hh^*00 + tt^*11. \quad \text{eqn. 5a}$$

In matrix form we have:

$$\begin{pmatrix} hh^* & ht^* \\ th^* & tt^* \end{pmatrix} \rightarrow \begin{pmatrix} hh^* & 0 \\ 0 & tt^* \end{pmatrix}. \quad \text{eqn. 5b}$$

The state,  $hh^*00 + t^*t11 + ht^*01 + h^*t10$ , can represent a pure state in quantum physics while the state,  $hh^*00 + tt^*11$ , represents what is called a “mixed” state. Usually one regards mixed states as representing one’s state of knowledge of, in this example, the quantum coin. Hence the mixed state is labeled as an epistemic state. The pure state is viewed either as an epistemic or ontic state depending on one’s point of view. In what follows I will follow Deutsch’s “closed timelike line” presentation<sup>20</sup> and shall label the mixed state, the state with no off-diagonal terms in the density matrix, as an ontic state—hence a state of real “out there” objectivity. Since one normally never observes off-diagonal elements of a density matrix, e.g., in this case either the state  $ht^*01$  or  $h^*t10$ , one might assume the full density matrix,  $hh^*00 + t^*t11 + ht^*01 + h^*t10$ , represents an epistemic state.<sup>21</sup> I’ll take this position although it is not necessary in what follows. The important step is to regard the mixed state,  $hh^*00 + tt^*11$ , as one that has actually been observed. One might ask how since one never sees both heads and tails simultaneously (unless one may have taken psychedelic mushrooms or LSD). The only answer Deutsch (and I concur) that makes sense is the observations occur in parallel universes. Hence consciousness provides evidentiary proof of complex closed “timelike curves connected parallel universes making up a conscious multiverse.

---

<sup>20</sup> Deutsch, David. “Quantum Mechanics near Closed Timelike Lines,” *Physical Review D* 44: 10 (November 15, 1991), pp. 3197–3217.

<sup>21</sup> Here I may differ with many readers. I take “epistemic” to mean what we think or imagine is “out there” not necessarily just what probabilities we assign to “out there-ness.”

## WHAT ARE CTCs?

Probably the first physicist to come up with the idea of using Closed Timelike Curves (**CTCs**) was David Deutsch (he called them closed timelike lines). In his seminal work, Deutsch introduces a model for the analysis of the physical behavior of **CTCs**. Prior to his work; the standard way of analyzing the physical effects of chronology-violating regions of spacetime was in terms of their underlying geometry, specifically as found in the general theory of relativity. Deutsch considered this approach to be insufficient because it fails to take quantum mechanical effects into account. He proposed an alternative approach which involves analyzing the behavior of **CTCs** in terms of their information-processing capabilities, by redescribing the information flow of the physical situation in the form of qubits following a quantum computational circuit.

His proposal involves translating all spacetime-bounded networks into logical circuits in which each particle or qubit traveling in the original network is replaced by sufficiently many carrier qubits to encode the information flow. The regions in which the particles interact are called gates. The states of the particles do not change while outside such gates. And finally, all chronology-violating effects of the network are localized to sufficiently many carrier particles on closed loops, which only interact with chronology-respecting particles while passing through these gates.

Introducing **CTCs** in the classical (non-quantum) case, networks containing chronology violations can lead to paradoxes that seem to put unnaturally strong constraints on possible initial conditions of physical systems (e.g. you are somehow prohibited from getting in the time machine that would take you back to kill your grandfather). Deutsch uses his model to argue that, when quantum mechanics is taken into account, these unnatural constraints on initial states disappear. Deutsch's fixed point theorem<sup>22</sup> states that **CTCs** “place no retrospective constraints on the state of a quantum system.” That is to say, for any possible input state, there will always be a paradox-free consistent solution.

Deutsch argued that, under certain consistency conditions (which I'll come to shortly), quantum mechanics can solve the paradoxes associated with time travel to the past. What bothered Deutsch about the classical solutions to these paradoxes was that certain initial states of systems are ruled out by these classical solutions, in order to be globally consistent. This is at odds with what Deutsch identifies as one of the fundamental principles of the philosophy of science: that global constraints should not overrule our ability to act locally in accord with the laws of physics. He calls this the

---

<sup>22</sup> In mathematics a fixed point describes a simple situation where for any function  $f(x)$  there exists a value of  $x$ , say  $a$ , such that  $f(a)=a$ . Any function that has such a point is labeled as a fixed point.



autonomy principle.<sup>23</sup> Whereas the classical consistency condition violates this principle by disallowing certain initial trajectories of systems traveling along **CTCs**.

### METAPHYSICS OF DEUTSCH'S CTCs?<sup>24</sup>

Paradox-free solutions are achieved by allowing for mixed quantum states to occur on the **CTC**; a strategy to which solutions in the classical setting do not have access. These mixed states represent, for Deutsch, a collection of worlds, or “multiverse.” However, Deutsch is relying on the existence of a more general notion of the multiverse, wherein the universes are not generated as the result of any evolutionary equation such as the Schrödinger, Dirac, or quantum field-theoretical evolution of the universal wavefunction, leading to the branching-off of macroscopic worlds, as in the standard Everett picture. Rather, the individual universes in this case exist timelessly and in parallel, many identical with one another for at least some period of time. These are not the many worlds of the Everett interpretation.

Deutsch’s vision of parallel universes sheds light on the issue of ontic and epistemic states. It is particularly important when considering **CTCs** because the interpretation of quantum states as either ontic or epistemic will naturally lead to different assumptions about how quantum systems behave in the presence of **CTCs**. For example, Deutsch studied various time travel scenarios in a classical model and then in a quantum model motivated by an ontic interpretation of quantum states (specifically, what I label as the Deutsch- Everett interpretation).

### CONSCIOUSNESS AND CTCs

To examine how **CTCs** may resolve the old collapse of the quantum wave function issue, I shall look first into part I: four specific scenarios using two qubit input states and finally in part II: a situation first envisioned by Bennett *et al*<sup>25</sup> involving two cases having one half of a Bell-type entangled state entering a **Swap** gate together a **CTC** qubit: In the first of these entangled cases, IIa, labeled a single universe picture, we have three input qubits. In the final case, IIb, labeled a parallel universe picture, we have six input qubits: three in each universe.

I will use the ◀ symbol to represent the output mouth of a wormhole (that takes place

---

<sup>23</sup> See Deutsch, David and Lockwood, Michael. “The Quantum Physics of Time Travel.” *Sci. Am.* March, 1994.

<sup>24</sup> Dunlap, Lucas. The Metaphysics of D-CTCs: On the Underlying Assumptions of Deutsch's Quantum Solution to the Paradoxes of Time Travel arXiv: 1510.02742v1 [quant-ph] 9 Oct 2015.

<sup>25</sup> Bennett, C. H., Leung D., Smith G., and Smolin, J. A. *Phys. Rev. Lett.* **103**, 170502 (2009).

in the past) and the  $\blacktriangleright$  symbol to represent the input mouth of the same wormhole (that occurs in the future). If the mouths are different rails, I will identify them with identical colors. Hence a diagram for a wormhole would appear as,



Fig. 9. Wormhole diagram used in quantum computer circuits.

with time running from left to right. The key insight here is to identify what comes out of the past  $\blacktriangleleft$  is simultaneously with what goes into the future  $\blacktriangleright$  for any particle or qubit traveling through the wormhole. For a time traveler on such a trajectory these mouths are simultaneously occurring, while for others outside the wormhole the output mouth  $\blacktriangleleft$  takes place in the past while the input mouth  $\blacktriangleright$  takes place in the future. Hence such a line,  $\blacktriangleleft\text{---}\blacktriangleright$ , is really a closed timelike trajectory.

In what follows I hope to show how quantum wave function collapse resulting in conscious observation can be understood using **CTCs**. I should point out that **CTCs** do not universally resolve this question. Hence it may be that only certain **CTC** circuits may apply—those that produce a striping of off-diagonal elements of input density matrices and those **CTCs** that are themselves consequently in a mixed state (diagonal elements only).

I'll begin by examining several cases including finally the case of a two-qubit entangled state together with a qubit in a **CTC**. Here the Deutsch-Everett picture shows that a typical Bell-type entangled state becomes unentangled after passing through a gate containing the **CTC** in a single universe, but remains entangled with its partner in a parallel universe.

## Part I Four Two Qubits

Let me start with the simplest four cases of one pure state qubit together with a, to be determined, qubit in a **CTC** which may be the pure state qubit itself after passing through the future wormhole. I shall assume that the input qubit always has the form as given by eqn. 3 (it may be inputted in the first or second rail):

$$R_{1 \text{ or } 2} = \alpha\alpha^*00 + \beta\beta^*11 + \alpha\beta^*01 + \beta\alpha^*10, \quad \text{eqn. 6a}$$

and the **CTC** qubit, which also may evolve along one or another or both rails (i.e., inputting on one rail but outputting on the other rail), has the form:

$$S_{1 \text{ or } 2} = a00 + c11 + b01 + b^*10. \quad \text{eqn. 6b}$$

I shall not assume that  $b=ac^*$  as would be the case for a pure input qubit. However it is always the case that  $a+c=1$  where both  $a$  and  $c$  are real, each greater or equal to zero and less than or equal to one. The unitary gate<sup>26</sup> has the **C-NOT** form:

$$U = 00 \otimes I \oplus 11 \otimes X. \quad \text{eqn. 6c}$$

We then use the consistency condition of taking the appropriate trace of  $UR_1 \otimes R_2 U^\dagger$  over the output rail that doesn't enter into a wormhole mouth and setting it equal to the output from the input wormhole mouth. So let me explicitly show these relations for the next four cases.

### CTCs that Work and Don't Work to Produce Consciousness

Case a.

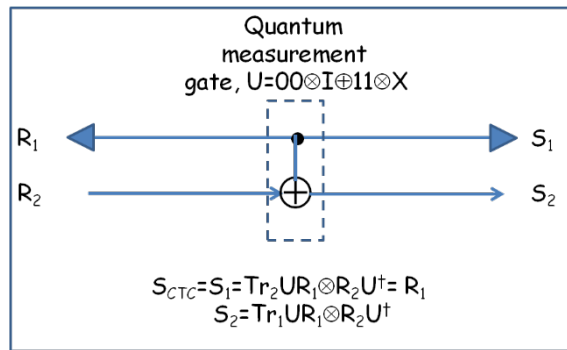

Fig. 9a. **CTC** circuit with ► representing wormhole input port and ◄ representing wormhole output port.

<sup>26</sup> All gates are assumed to be unitaries.

In Fig. 9a following the Deutsch procedure we indentify  $\mathbf{S}_{\text{CTC}}=\mathbf{S}_1$  with  $\mathbf{R}_1$ . We find:

$$\mathbf{S}_{\text{CTC}}=\mathbf{S}_1=\mathbf{R}_1=\text{Tr}_2[\mathbf{U}\mathbf{R}_1\otimes\mathbf{R}_2\mathbf{U}^\dagger]=a\mathbf{00}+c\mathbf{11}. \quad \text{eqn. 7a}$$

We also find (always using  $|\alpha|^2+|\beta|^2=1$ ) for the output qubit:

$$\begin{aligned} \mathbf{S}_2 &= \text{Tr}_1[\mathbf{U}\mathbf{R}_1\otimes\mathbf{R}_2\mathbf{U}^\dagger]= \\ & (a|\alpha|^2+c|\beta|^2)\mathbf{00}+(c|\alpha|^2+a|\beta|^2)\mathbf{11}+(a\alpha\beta^*+c\beta\alpha^*)\mathbf{01}+(c\alpha\beta^*+a\beta\alpha^*)\mathbf{10}. \end{aligned} \quad \text{eqn. 7b}$$

Here the **CTC** qubit has the mixed state format. However it fails to strip the input qubit of its off-diagonal elements, since the output qubit  $\mathbf{S}_2$  has off-diagonal elements. Deutsch recognized this as an “uneven” situation, wherein since  $a$  and  $c$  are undetermined probabilities (they can be any positive numbers such that  $a+c=1$ ), and thus assumes that an additional maximum entropy condition holds for the **CTC** qubit state, wherein  $a=c=1/2$ . Consequently we find:

$$\mathbf{S}_2=\text{Tr}_1[\mathbf{U}\mathbf{R}_1\otimes\mathbf{R}_2\mathbf{U}^\dagger]=\frac{1}{2}\{\mathbf{I}+(\alpha\beta^*+\beta\alpha^*)\mathbf{X}\}. \quad \text{eqn. 7c}$$

If the condition defining the input state  $\mathbf{R}_2$  was such that  $(\alpha\beta^*+\beta\alpha^*)=0$ ,  $\mathbf{S}_2$  would indeed be diagonal and equal to the **CTC** qubit state,  $\frac{1}{2}\mathbf{I}$ . We’ll come back to this later. Here we point out that there are many fixed point solutions for  $a$  and  $c$ . Had we chosen the case  $a=1$  ( $c=0$ ) we would find from eqn. 7b,  $\mathbf{S}_2=\mathbf{R}_2$  as given by eqn. 3. Similarly, if we had the case  $c=1$ , we would get the flipped bit solution for  $\mathbf{S}_2$  given by eqn. 4. Hence in either case ( $a=1$ ,  $c=0$ ) or ( $a=0$ ,  $c=1$ ) the consistency condition applied to the controlling **CTC** qubit (rail 1) acts the same as the non-**CTC** rail 1 shown in Fig. 8. This is no surprise since the controlling qubit in rail 1 doesn’t change after passing through the gate regardless. Since this configuration fails to generally produce a mixed output density matrix, we find it wouldn’t work to produce an action of consciousness. So mark case  $a$  as a general failure.

CASE B.

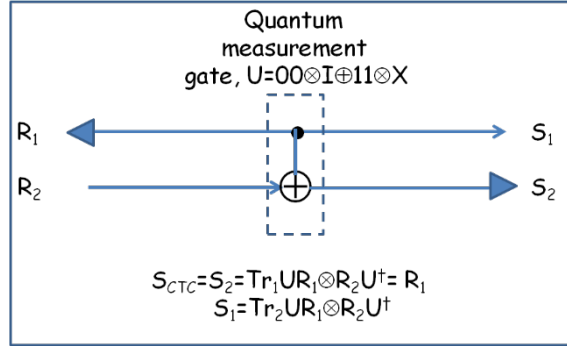

Fig. 9b CTC.

In Fig. 9b we identify  $S_{CTC}=S_2$  with  $R_1$ . We find:

$$S_{CTC}=S_2=R_1=\text{Tr}_1[UR_1\otimes R_2U^\dagger]=\frac{1}{2}\{I+(\alpha\beta^*+\beta\alpha^*)X\}. \quad \text{eqn. 7d}$$

Here using eqn. 7d we find a and c are determined probabilities and find the fixed point solution:  $a=c=\frac{1}{2}$  and  $b=b^*=0$ .

Consequently we find (where as usual,  $|\alpha|^2+|\beta|^2=1$ ):

$$S_1=\text{Tr}_2[UR_1\otimes R_2U^\dagger]=\frac{1}{2}\{I+(\alpha\beta^*+\beta\alpha^*)^2X\}. \quad \text{eqn. 7e}$$

Deutsch examined this case in his seminal CTC paper.<sup>27</sup> Although interesting it also fails to produce a pure diagonal output density matrix,  $S_1$ , in the general case. In effect the input qubit  $R_2$  enters the wormhole travels back in time to exit in the past where it provides a control for its earlier self before exiting the gate as  $S_1$ .

In the special case where  $(\alpha\beta^*+\beta\alpha^*)=0$  as when, e.g.,  $\alpha=|\alpha|$  and  $\beta=i|\beta|$ , we get  $|\alpha|(|\beta^*+\beta|)=0$  for both outputs in cases a and b shown in Figs.9a and 9b. In the special

<sup>27</sup> Deutsch, D. *op. cit.*

case where  $|\alpha|=|\beta|=1/\sqrt{2}$  we see that the pure input state is an eigenstate of  $\sigma_y$ . For this special case we find success. However we are seeking specifically general solutions wherein both  $\mathbf{S}_1$  and  $\mathbf{S}_2$  are diagonal.

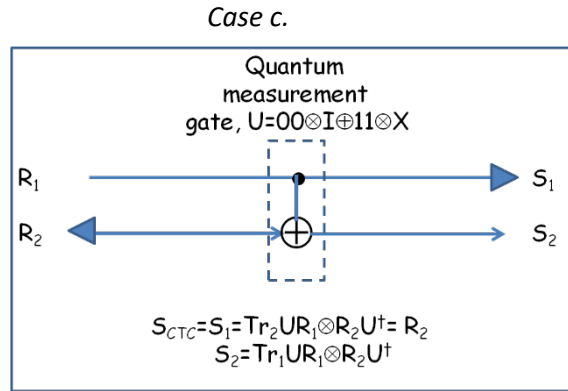

Fig. 9c CTC.

In Fig. 9c we identify  $\mathbf{S}_{CTC}=\mathbf{S}_1$  with  $\mathbf{R}_2$ . We find:

$$\mathbf{S}_{CTC}=\mathbf{S}_1=\mathbf{R}_2=Tr_2[\mathbf{U}\mathbf{R}_1\otimes\mathbf{R}_2\mathbf{U}^\dagger]=|\alpha|^2\mathbf{00}+|\beta|^2\mathbf{11}, \quad \text{eqn. 7f}$$

Here using eqn. 7f we find a and c are determined probabilities:  $a=|\alpha|^2$ ,  $c=|\beta|^2$  and  $b=b^*=0$ .

Consequently we find (where as usual,  $|\alpha|^2+|\beta|^2=1$ ):

$$\mathbf{S}_2=Tr_1[\mathbf{U}\mathbf{R}_1\otimes\mathbf{R}_2\mathbf{U}^\dagger]=(|\alpha|^4+|\beta|^4)\mathbf{00}+2|\alpha\beta|^2\mathbf{11}. \quad \text{eqn. 7g}$$

Ralph examined this case in his CTC paper.<sup>28</sup> Here we get the desired result; both  $\mathbf{S}_{CTC}$  and  $\mathbf{S}_2$  are indeed diagonal matrices. We then interpret this result by saying  $\mathbf{S}_2$  produces ontic outputs in parallel universes according to probabilities  $(|\alpha|^4+|\beta|^4)$  for

---

<sup>28</sup> Ralph, T.C. Unitary Solution to a Quantum gravity Information paradox. ArXiv: 0708.0449v1 [quant-ph] 3 Aug 2007.

the  $\mathbf{00}$  state and  $2|\alpha\beta|^2$  for the  $\mathbf{11}$  state. For the case where  $|\alpha|^2=|\beta|^2=1/2$ , we get equal probabilities for these two outputs. Here we find the **CTC** producing the desired result with output  $\mathbf{S}_2$  containing no off-diagonal elements corresponding to the ontic representation or conscious state in parallel universes.

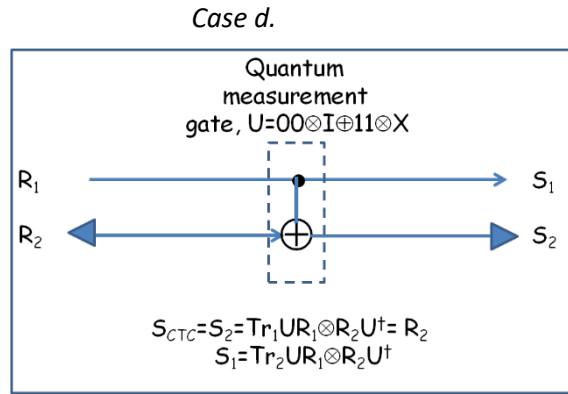

Fig. 9d **CTC**.

In Fig. 9d we identify  $S_{CTC}=S_2$  with  $R_2$ . We find:

$$S_{CTC}=S_2=R_2=Tr_1[UR_1\otimes R_2U^\dagger]=\frac{1}{2}(I+\lambda X), \quad \text{eqn. 7h}$$

where  $\lambda$  is real and  $0\leq\lambda\leq 1$ . Here using eqn. 7h we find  $a$  and  $c$  are determined probabilities:  $a=c=1/2$  and  $b=b^*=\lambda/2$ . Consequently we find (where as usual,  $|\alpha|^2+|\beta|^2=1$ ):

$$S_1=Tr_2[UR_1\otimes R_2U^\dagger]=|\alpha|^2\mathbf{00}+|\beta|^2\mathbf{11}+\lambda(\alpha\beta^*\mathbf{01}+\beta\alpha^*\mathbf{10}). \quad \text{eqn. 7i}$$

The desired solution would have  $\lambda=0$  wherein both  $S_1$  and  $S_2$  are diagonal and mixed states. This solution also corresponds to Deutsch's maximum entropy **CTC** state. In this case we find the **CTC** producing the desired result with output  $S_2$  containing no off-diagonal elements corresponding to the ontic representation or conscious state in parallel universes. For  $\lambda=1$ ,  $S_1=R_1$ , whereas the **CTC** qubit plays no role and the pure

input state qubit passes through the gate as if the **CTC** qubit wasn't present.

So summing up: In cases a, c, and d we find  $S_{\text{CTC}}$  equal to a mixed state, given Deutsch's maximum entropy rule being applied in case d. The output state for a pure input state is also mixed in case c and in case d when the maximum entropy rule is applied.

### Part II a-Single Universe Picture

Next we'll consider in part IIa what occurs when an entangled Bell-type state encounters a **CTC** and the **Swap** gate.

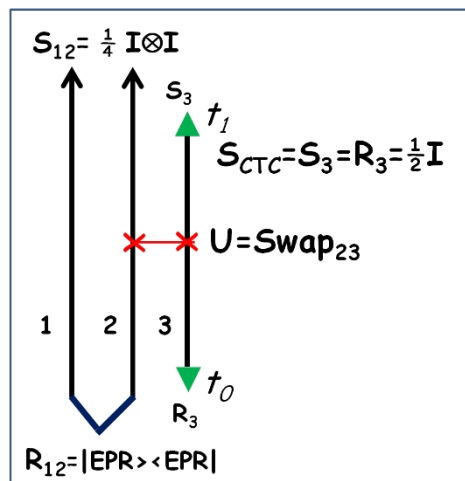

Fig. 10a. A single universe action.

This scenario was first looked at by Charles H. Bennett and his associates.<sup>29</sup> They considered what happens when one sends half of an **EPR** pair along a **CTC** that interacts with that half of the **EPR** Bell-type pair with a **Swap** gate. The unitary  $\text{Swap}_{23}$  and the results of the calculations using one particular **EPR** Bell-type entangled state are given by:

<sup>29</sup> Bennett, C. H., *et al*, *op. cit.*



$$\mathbf{U}=\text{Swap}_{23}=(\mathbf{00}\otimes\mathbf{00}+\mathbf{11}\otimes\mathbf{11}+\mathbf{10}\otimes\mathbf{01}+\mathbf{01}\otimes\mathbf{10}),$$

$$\mathbf{S}_{\text{CTC}}=\mathbf{S}_3=\mathbf{R}_3=\text{Tr}_{1,2}[\mathbf{U}\mathbf{R}_{12}\otimes\mathbf{R}_3\mathbf{U}^\dagger]=\frac{1}{2}\mathbf{I}, \text{ and, } \mathbf{S}_{12}=\text{Tr}_3[\mathbf{U}\mathbf{R}_{12}\otimes\mathbf{R}_3\mathbf{U}^\dagger]=\frac{1}{4}\mathbf{I}\otimes\mathbf{I},$$

$$\text{with, e.g., } \mathbf{R}_{12}=|\text{EPR}\rangle\langle\text{EPR}|=\frac{1}{2}(|\mathbf{0}\rangle|\mathbf{1}\rangle+|\mathbf{1}\rangle|\mathbf{0}\rangle)\otimes(|\mathbf{0}\rangle\langle\mathbf{0}|+|\mathbf{1}\rangle\langle\mathbf{1}|),$$

$$\frac{1}{2}(\mathbf{00}\otimes\mathbf{11}+\mathbf{11}\otimes\mathbf{00}+\mathbf{10}\otimes\mathbf{01}+\mathbf{01}\otimes\mathbf{10}). \quad \text{eqns. 8a}$$

Actually any Bell-type **EPR** entangled state works here. Bennett *et al* label this scenario as the “single universe” picture wherein an **EPR** pair is created in the distant past. At time  $t_0$  a qubit emerges from the **CTC** and at time  $t_i$  half of the **EPR** pair is swapped with the **CTC** qubit. According to Deutsch’s prescription the density matrix of the **CTC** system,  $\mathbf{S}_3$ , at  $t_0$  is equal to the **CTC** density matrix,  $\mathbf{R}_3$ , at  $t_i$ . The only consistent, i.e., fixed point solution for  $\mathbf{S}_3$  is  $\frac{1}{2}\mathbf{I}$ . Consequently the joint state at any time after  $t_i$  is a product state,  $\frac{1}{4}\mathbf{I}\otimes\mathbf{I}$ . Here we see the complete disentanglement of the maximally entangled **EPR** input state.

If we envision the original Bell-type state—an entanglement of the **o** and **i** states—by supposing that the **o** state corresponds to heads appearing on a coin and **i** corresponding to tails, we find emerging from the gate, four possible parallel universes with the disentangled ontological results:

$$\mathbf{S}_{12}=\frac{1}{4}\mathbf{I}\otimes\mathbf{I}=\frac{1}{4}(\mathbf{00}+\mathbf{11})\otimes(\mathbf{00}+\mathbf{11})=\frac{1}{4}(\mathbf{00}\otimes\mathbf{00}+\mathbf{11}\otimes\mathbf{00}+\mathbf{00}\otimes\mathbf{11}+\mathbf{11}\otimes\mathbf{11}) \quad \text{eqn. 8b}$$

Perhaps surprisingly following Deutsch-Everett we end up with four distinct and equally likely scenarios or parallel universes as seen in Fig. 10b.

Correspondingly, in the collapse formulation, this is exactly what would be seen upon observations of a single coin by each of two separate observers of the entangled pair, i.e.,

$$(\text{Tr}_2 \text{ or } \text{Tr}_1)[\frac{1}{2}(\mathbf{00}\otimes\mathbf{11}+\mathbf{11}\otimes\mathbf{00}+\mathbf{10}\otimes\mathbf{01}+\mathbf{01}\otimes\mathbf{10})]=\frac{1}{2}\mathbf{I}=\frac{1}{2}(\text{heads}+\text{tails}), \quad \text{eqn. 8c}$$

with a similar result for the other coin. Each observer traces over the other’s possibilities to gain an observation and each ends up with no knowledge of the other’s coin. The advantage of using the **CTC** formulation is that the four observational states emerge with no collapse envisioned.

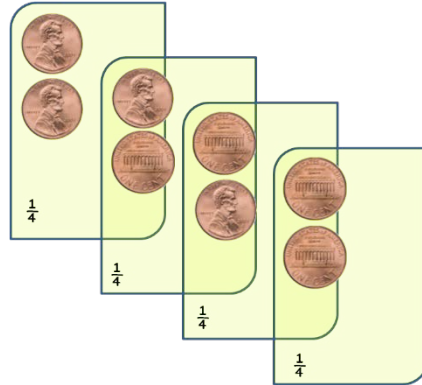

Fig. 10b. Four equally likely ontological parallel universes.

### Part IIb-Parallel Universe Picture

What happens if we envision the **EPR** pairs being created in two parallel universes to start? We see the results next in Fig. 11.

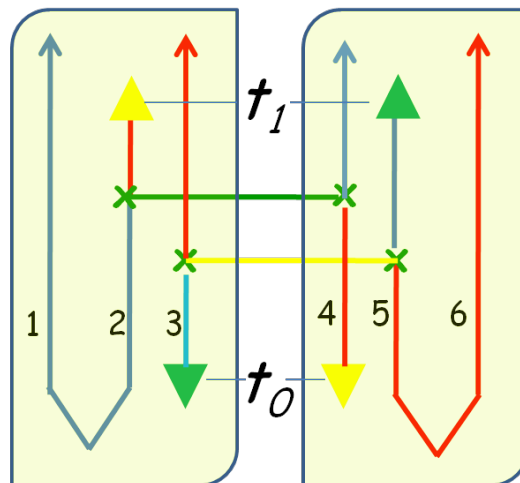

Fig. 11. A parallel universes picture of entangled **EPR** pairs encountering **CTCs** in parallel universes connected by double **Swaps**.

Bennett *et al* next consider a parallel universes picture as shown in Fig. 11. Although

they didn't work out or indicate how to map the quantum computational circuits, I have created the map shown in Fig. 11 and the corresponding eqns. for the circuit diagrams. It appears that control or communication from one universe to another is possible in this scheme. Let me explain how Fig. 11 works. We have a pair of wormholes (time machines) in operation connecting the two universes. One wormhole is symbolized by the two opposite facing yellow triangles on rails 2 and 4, and similarly the other by two green triangles on rails 3 and 5. Thus yellow (green) triangles indicate entering and exiting in different universes separated in Fig. 11. In each universe two identically entangled Bell-type **EPR** qubits are produced. Time flow is up the page and the 2<sup>nd</sup> particle of each correlated pair (produced in its own universe) enters a future wormhole in its own universe but emerges back in time in the other universe. What happens here is a bit complex but in any universe the two particles, emerging in the future with opposite colored rails, in each universe are completely free of each other (product states), while the two particles with the same color in different universes are still correlated (**EPR**-entangled).

Here are the details (Also see footnote 30.): In both universes the **EPR** pair is created in the distant past ( $\mathbf{R}_{12}$  and  $\mathbf{R}_{56}$ ). At time  $t_0$  a qubit emerges from the **CTC** in each universe. At time  $t_i$  in each universe half of each **EPR** pair is put into the **CTC** and goes back in time to emerge at  $t_0$  in the other universe. Each **EPR** particle originally created (as e.g.,  $\mathbf{R}_1$ , and emerging as  $\mathbf{S}_1$ ) is entangled with a partner in the other universe (e.g., originally created as  $\mathbf{R}_2$  but emerging as  $\mathbf{S}_4$ ) and each **EPR** pair,  $\mathbf{R}_{12}$  and  $\mathbf{R}_{56}$ , emerging in a product state (e.g.,  $\mathbf{S}_1$  with the other particle originally created as  $\mathbf{R}_5$  but emerging as  $\mathbf{S}_3$  in its own universe. Here the unitary double **Swaps** and the corresponding trace eqns. are<sup>30</sup>:

---

<sup>30</sup> The full 16 term traceable quantity  $\mathbf{UR}_{12}\otimes\mathbf{R}_3\otimes\mathbf{R}_4\otimes\mathbf{R}_{56}\mathbf{U}^\dagger=$   
 $(00\otimes|00\otimes11\otimes|11+11\otimes11\otimes|00+10\otimes11\otimes|01+01\otimes11\otimes|10]+$   
 $11\otimes|00\otimes00\otimes|11+11\otimes00\otimes|00+10\otimes00\otimes|01+01\otimes00\otimes|10]+$   
 $10\otimes|00\otimes01\otimes|11+11\otimes01\otimes|00+10\otimes01\otimes|01+01\otimes01\otimes|10]+$   
 $01\otimes|00\otimes10\otimes|11+11\otimes10\otimes|00+10\otimes10\otimes|01+01\otimes10\otimes|10])/16.$

$$\mathbf{U}=\text{Swap}_{24}\cdot\text{Swap}_{35},$$

$$\mathbf{S}_{\text{CTCa}}=\mathbf{S}_2=\mathbf{R}_4=\text{Tr}_{1,3,4,5,6}[\mathbf{U}\mathbf{R}_{12}\otimes\mathbf{R}_3\otimes\mathbf{R}_4\otimes\mathbf{R}_{56}\mathbf{U}^\dagger]=\frac{1}{2}\mathbf{I}, \text{ and,}$$

$$\mathbf{S}_{\text{CTCb}}=\mathbf{S}_5=\mathbf{R}_3=\text{Tr}_{1,2,3,4,6}[\mathbf{U}\mathbf{R}_{12}\otimes\mathbf{R}_3\otimes\mathbf{R}_4\otimes\mathbf{R}_{56}\mathbf{U}^\dagger]=\frac{1}{2}\mathbf{I},$$

$$\mathbf{S}_{13}=\text{Tr}_{2,4,5,6}[\mathbf{U}\mathbf{R}_{12}\otimes\mathbf{R}_3\otimes\mathbf{R}_4\otimes\mathbf{R}_{56}\mathbf{U}^\dagger]=\frac{1}{4}\mathbf{I}\otimes\mathbf{I},$$

$$\mathbf{S}_{46}=\text{Tr}_{1,2,3,5}[\mathbf{U}\mathbf{R}_{12}\otimes\mathbf{R}_3\otimes\mathbf{R}_4\otimes\mathbf{R}_{56}\mathbf{U}^\dagger]=\frac{1}{4}\mathbf{I}\otimes\mathbf{I},$$

$$\text{with, e.g., } \mathbf{R}_{12}=\mathbf{R}_{56}=|\text{EPR}\rangle\langle\text{EPR}|=\frac{1}{2}(|\mathbf{0}\rangle|\mathbf{1}\rangle+|\mathbf{1}\rangle|\mathbf{0}\rangle)\otimes(\langle\mathbf{0}| \langle\mathbf{1}|+\langle\mathbf{1}| \langle\mathbf{0}|)=$$

$$\frac{1}{2}(\mathbf{00}\otimes\mathbf{11}+\mathbf{11}\otimes\mathbf{00}+\mathbf{10}\otimes\mathbf{01}+\mathbf{01}\otimes\mathbf{10}), \text{ and consequently,}$$

$$\mathbf{S}_{14}=\mathbf{S}_{36}=\frac{1}{2}(\mathbf{00}\otimes\mathbf{11}+\mathbf{11}\otimes\mathbf{00}+\mathbf{10}\otimes\mathbf{01}+\mathbf{01}\otimes\mathbf{10}), \quad \text{eqns. 9}$$

So briefly summarizing: Emerging in a single universe, part IIa, containing a **CTC** and a maximally entangled **EPR** chronological respecting qubit is a “mixed” pair of particles. But in a parallel universes (part IIb) model of this interaction, the particles remain entangled with each particle in separate universes.

What makes this case, part IIb, appealing is the current interest in what is called the **ER=EPR** question.<sup>31</sup> This conjecture states that entangled particles are connected by a wormhole (or **Einstein-Rosen Bridge**, hence **ER**). The conjecture was proposed by Leonard Susskind and Juan Maldacena in 2013.<sup>32</sup> They proposed that an Einstein-Rosen Bridge is equivalent to a non-traversable wormhole. This conjecture along with our conjecture in this paper sits uncomfortably with the linearity of quantum mechanics. An entangled state is a linear superposition of separable states. Presumably, separable states are not connected by any wormholes, but yet a superposition of such states is connected by a wormhole.

<sup>31</sup> Although I have used **EPR** throughout, I should mention that the letters stand for Einstein-Podolsky-Rosen who back in 1935 were concerned with the question of the completeness of quantum physics in their now classic paper: Einstein, A., Podolsky, B., Rosen, N.: “Can quantum-mechanical description of physical reality be considered complete?” *Phys. Rev.* **41**, 777 (15 May 1935). Later Einstein and Rosen wrote another classic paper: Einstein, A.; Rosen, N. “The Particle Problem in the General Theory of Relativity”. *Physical Review*. **48** (1): 73–77 (1 July 1935) in which the concept of a bridge between black holes was first introduced.  
<sup>32</sup> Maldacena, Juan; Susskind, Leonard (2013). “Cool horizons for entangled black holes”. *Fortsch. Phys.* 61: 781–811. ArXiv:1306.0533. Also see Susskind, Leonard (2016). “Copenhagen vs Everett, Teleportation, and ER=EPR”. arXiv:1604.02589. Susskind states “If we believe in the ambitious form of **ER=EPR**, this implies the presence of an Einstein-Rosen bridge connecting the superposed wave packets for a single particle.”

---

## CONCLUSION

“All the world’s a stage,” Shakespeare wrote, and we physicists tend to think that way too. Our stage happens to be spacetime itself, and to us, spacetime sometimes seems like a mere backdrop to the action of the forces and fields that inhabit it. Spacetime, accordingly, is not made up of anything at all, but stuff happens in it.

Sean M. Carroll in his July 18, 2016 blog,<sup>33</sup> “Space Emerging from Quantum Mechanics,” wrote: “A related notion is the **ER=EPR** conjecture of Maldacena and Susskind, relating entanglement to wormholes. They wrote, ‘In some sense, we’re making this proposal a bit more specific, by giving a formula for distance as a function of entanglement.’” I draw the implication from this conjecture that underlying spacetime itself lies a network of quantum computational networks with spacetime appearing as an interconnected multiverse emerging from **CTCs** as envisioned by Deutsch.

Here we have examined the Deutsch **CTC** connected multiverse picture and have begun to examine this spacetime pre-existent convention. Our examination, as if by magic, provides a role for consciousness as embedded in this pre-spacetime “verse.” I use the term “verse” to describe what comes even before we have a universe or multiverse. A verse is a network of quantum computational networks with spacetime emerging as an interconnected multiverse interconnected by mixed state **CTCs**. I ask you to consider that spacetime may actually be composed of tiny information-processing quantum computational networks transversable by qubits along both chronology respecting and chronology disrespecting rails. Here we examined how these circuits interact with one another as if they existed in a pre-spacetime algebraic universe, through the actions of wormholes allowing qubits to travel backwards-through-time making up **CTCs**.

---

<sup>33</sup> <http://www.preposterousuniverse.com/blog/2016/07/18/space-emerging-from-quantum-mechanics/> .

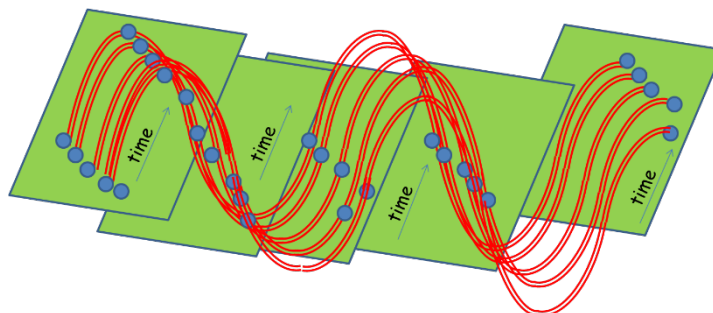

Fig. 12. The Multiverse as perhaps envisioned by David Deutsch connected by **CTC** wormholes.

Deutsch's **CTC** model, based on an ontic interpretation of quantum states, is particularly unconventional, in part because it requires that mixed quantum states are ontic. Although it is common for pure quantum states to be interpreted as ontic, most interpretations view mixed states as epistemic, i.e., reflecting an observer's lack of knowledge. Here I considered pure quantum states, represented by density matrices containing off-diagonal elements, are epistemic while mixed quantum states arising both in **CTCs** and on chronologically respecting qubit trajectories are ontic representing the action of consciousness of observers while not requiring any collapse *ad hoc* supposition ala von Neumann. Paradoxically my argument is based on a kind of commonsense classical physics—namely that mixed states (represented by diagonal density matrices in quantum physics but probability distributions in classical physics)—are just what arise when an “observation” is said to occur resulting in a so-called reduction of the quantum wave function and the appearance of a classical world. In brief, Deutsch's **CTC** nonlinear quantum physics model may represent the action of a conscious mind.

Founder and Director of Have Brains/Will Travel: a Global Quantum Physics Educational  
Company  
San Francisco CA, USA  
fred@fredalanwolf.com